PCB Layout and Design Guide for CH7025/CH7026 TV/VGA Encoder

1.0 Introduction

The CH7025/CH7026 is a device targeting handheld and similar systems which accept a digital input signal, and encodes and transmits data through three 10-bit DACs. The device is able to encode the video signals and generate synchronization signals for NTSC and PAL standards. Analog RGB output and composite SYNC signal are also supported. The device accepts different data formats including RGB and YCrCb (e.g. RGB565, RGB666, RGB888, ITU656 like YCrCb, etc.). 16Mbit SDRAM can be embedded in package, so Frame rate conversion and Image Rotation are possible.

This application note focuses only on the basic PCB layout and design guidelines for CH7025/CH7026 SDTV/VGA encoder. Guidelines in component placement, power supply decoupling, grounding, input/output signal interface are discussed in this document.

The discussion and figures that follow reflect and describe connections based on the 80-pin LQFP and BGA package of the CH7025/CH7026. Please refer to the CH7025/CH7026 datasheet for the details of the pin assignments.

2.0 Component Placement and Design Considerations

Components associated with the CH7025/CH7026 should be placed as close as possible to the respective pins. The following discussion will describe guidelines on how to connect critical pins, as well as describe the guidelines for the placement and layout of components associated with these pins.

2.1 Power Supply Decoupling

The optimum power supply decoupling is accomplished by placing a 0.1 μ F ceramic capacitor to each of the power supply pins as shown in **Figure 1**. These capacitors (C1, C2, C3, C4, C5, C6, C7) should be connected as close as possible to their respective power and ground pins using short and wide traces to minimize lead inductance. Whenever possible, a physical connecting trace should connect the ground pins of the decoupling capacitors to the CH7025/CH7026 ground pins, in addition to ground vias.

2.1.1 Ground Pins

The analog and digital grounds of the CH7025/CH7026 should be connected to a common ground plane to provide a low impedance return path for the supply currents. Whenever possible, each of the CH7025/CH7026 ground pins should be connected to its respective decoupling capacitor ground lead directly, then connected to the ground plane through a ground via. Short and wide traces should be used to minimize the lead inductance. See **Table 1** and **Table 2** for the Ground pins assignment.

2.1.2 Power Supply Pins

There are seven power supply pins, AVDD, AVDD_DAC, AVDD_PLL, VDDIO, DVDD, VDDQ, VDD_MEM. See **Table 1** for the Power supply pins assignment. See **Figure 1** for Power Supply Decoupling.

Table 1: Power Supply Pins Assignment of the CH7025/CH7026(LQFP)

Pin Assignment	# of Pins	Type	Symbol	Description
51	1	Power	VDDIO	IO supply voltage (1.2-3.3V)
69	1	Power	DVDD	Digital supply voltage (1.8V)
8,12,37,49	4	Power	AVDD	Analog supply voltage (2.5 – 3.3V)
33	1	Power	AVDD_PLL	PLL supply voltage (1.8V)
24,28	2	Power	AVDD_DAC	DAC power supply (2.5 – 3.3V)
10,18	2	Power	VDDQ_MEM	SDRAM output buffer supply voltage (2.5V)
14,44,45	3	Power	VDD_MEM	SDRAM device supply voltage (2.5V)
68	1	Ground	DGND	Digital supply ground
7,11,34,48	4	Ground	AGND	Analog supply ground
32	1	Ground	AGND_PLL	PLL supply ground
26,30	2	Ground	AGND_DAC	DAC supply ground
9,19	2	Ground	GNDQ	SDRAM output buffer supply ground
13,46,47	3	Ground	GND_MEM	SDRAM device supply ground

Table 2: Power Supply Pins Assignment of the CH7025/CH7026 (BGA)

Pin Assignment	# of Pins	Type	Symbol	Description
F8	1	Power	VDDIO	IO supply voltage (1.2-3.3V)
B6	1	Power	DVDD	Digital supply voltage (1.8V)
D1, F1, L7, G9	4	Power	AVDD	Analog supply voltage (2.5 – 3.3V)
K6	1	Power	AVDD_PLL	PLL supply voltage (1.8V)
K4	1	Power	AVDD_DAC	DAC power supply (2.5 – 3.3V)
E2, H1	2	Power	VDDQ	SDRAM output buffer supply voltage (2.5V)
G2, J8, H6	3	Power	VDD_MEM	SDRAM device supply voltage (2.5V)
A6	1	Ground	DGND	Digital supply ground
F4, F2, L6, G8	4	Ground	AGND	Analog supply ground
K5	1	Ground	AGND_PLL	PLL supply ground
K3	1	Ground	AGND_DAC	DAC supply ground
E1, J1	2	Ground	GNDQ	SDRAM output buffer supply ground
F3, H9, H8	3	Ground	GND_MEM	SDRAM device supply ground

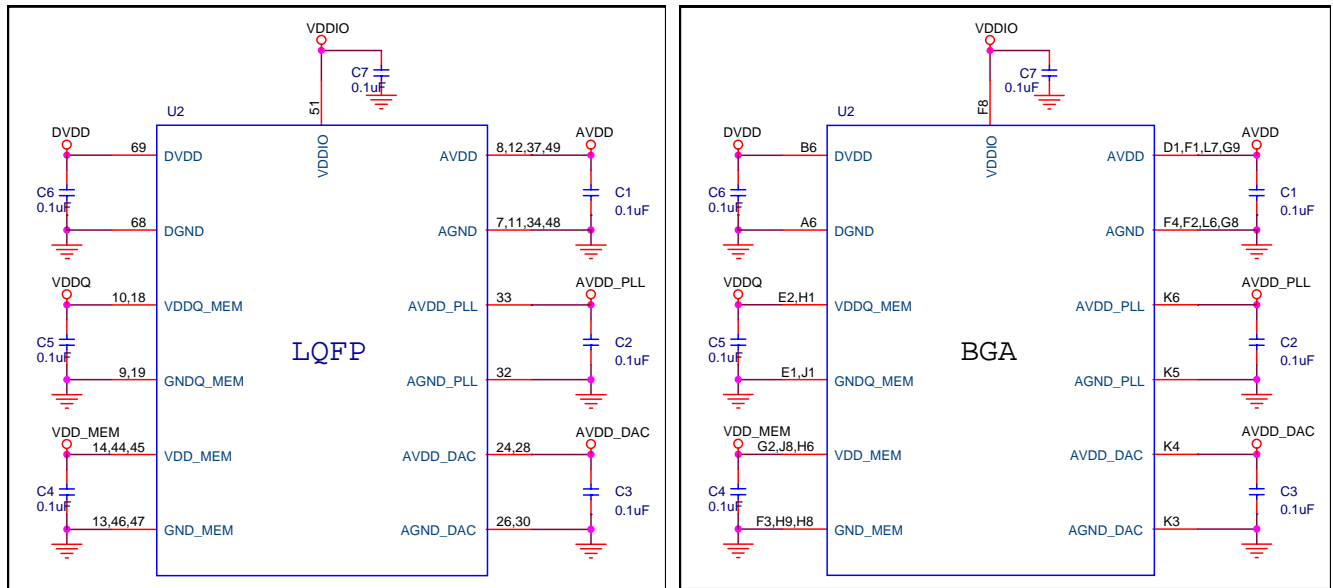

(a) LQFP Package

(b) BGA Package

Figure 1: Power Supply Decoupling and Distribution

Note: All the Ferrite Beads described in this document are recommended to have an impedance of less than 0.05 Ω at DC; 23 Ω at 25MHz & 47 Ω at 100MHz. Please refer to Fair Rite part #2743019447 for details or an equivalent part can be used for the diagram.

2.2 Internal Reference Pins

• ISET pin

This pin sets the DAC current. A 1.2 k Ω , 1% tolerance resistor should be connected between ISET and AGND_DAC as shown in **Figure 2**. A smaller resistance will create more DAC current, resulting brighter TV out images. This resistor should be placed with short and wide traces as near as possible to CH7025/CH7026.

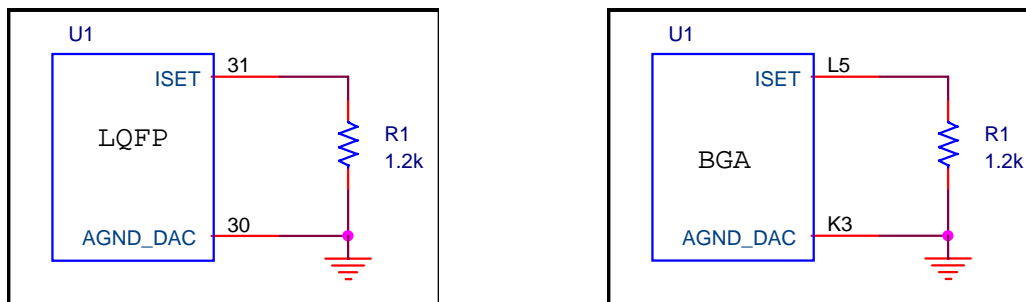

(a) LQFP Package

(b) BGA Package

Figure 2: ISET pin connection

2.3 General Control Pins

• RESETB

This pin is the chip reset pin for CH7025/CH7026. RESETB pin, which is internally pulled-up, places the device in the power on reset condition when this pin is low. A power reset switch can be placed on the RESETB

pin on the PCB as a hardware reset for CH7025/CH7026 as shown in **Figure 3**. When the pin is high, the reset function can also be controlled through the serial port.

• **XI and XO**

CH7025/CH7026 has capability to accept external clocks with frequencies from 2.3 MHz to 64 MHz. However, we recommend predefined crystal frequencies as stated in the CH7025/CH7026 datasheet for the crystal or oscillator.

Predefined crystal frequencies used for CH7025/CH7026 are shown in **Table 3**. The crystal selection register is located at Register 41h.

Table 3: Predefined Crystal Frequencies

XTAL[3:0]	Frequency
0	3.6864MHz
1	3.579545MHz
2	4MHz
3	12MHz
4	13MHz
5	13.5MHz
6	14.318MHz
7	14.7456MHz
8	16MHz
9	18.432MHz
10	20MHz
11	26MHz
12	27MHz
13	32MHz
14	40MHz
15	49MHz

The crystal load capacitance, C_L , is usually specified in the crystal spec from the vendor. As an example to show the load capacitors **Figure 3** gives a reference design for crystal circuit design.

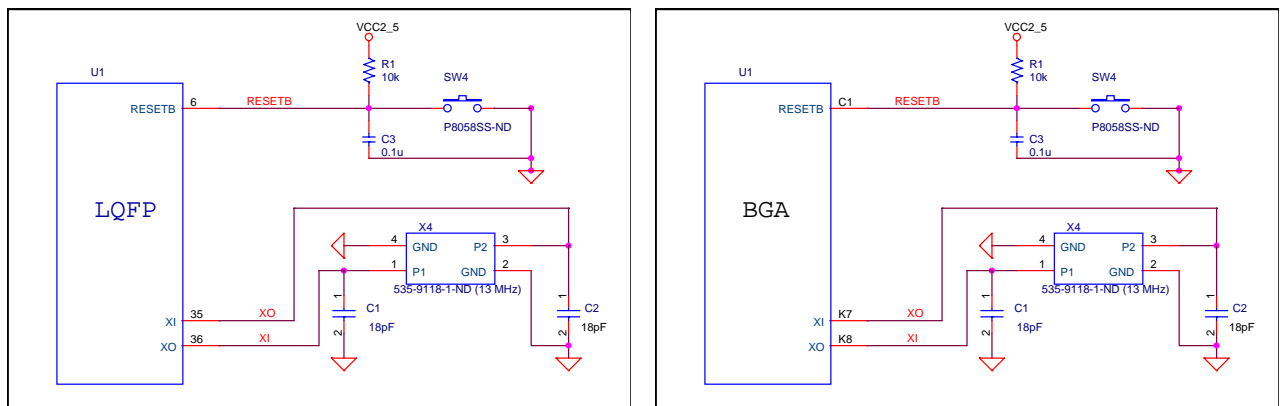

(a) LQFP Package

(b) BGA Package

Figure 3: General Control Pins

• Reference Crystal Oscillator

CH7025/CH7026 includes an oscillator circuit that allows a predefined-frequency crystal to be connected directly. Alternatively, an externally generated clock source may be supplied to CH7025/CH7026. If an external clock source is used, it should have CMOS level specifications. The clock should be connected to the XI pin, and the XO pin should be left open. The external source must exhibit ± 20 ppm or better frequency accuracy, and have low jitter characteristics.

If a crystal is used, the designer should ensure that the following conditions are met:

The crystal is specified to be predefined-frequency, ± 20 ppm fundamental type and in parallel resonance (NOT series resonance). The crystal should also have a load capacitance equal to its specified value (C_L).

External load capacitors have their ground connection very close to CH7025/CH7026 (C_{ext}).

To be able to tune, a variable capacitor may be connected from XI to ground.

Note that the XI and XO pins each has approximately 10 pF (C_{int}) of shunt capacitance internal to the device. To calculate the proper external load capacitance to be added to the XI and XO pins, the following calculation should be used:

$$C_{ext} = (2 \times C_L) - C_{int} - 2C_S$$

where

C_{ext} = external load capacitance required on XI and XO pins.

C_L = crystal load capacitance specified by crystal manufacturer.

C_{int} = capacitance internal to CH7025/CH7026 (approximately 10-15 pF on each of XI and XO pins).

C_S = stray capacitance of the circuit (i.e. routing capacitance on the PCB, associated capacitance of crystal holder from pin to pin etc.).

In general,

$$C_{int-XI} = C_{int-XO} = C_{int}$$

$$C_{ext-XI} = C_{ext-XO} = C_{ext}$$

such that

$$C_L = (C_{int} + C_{ext}) / 2 + C_S \text{ and } C_{ext} = 2(C_L - C_S) - C_{int} = 2C_L - (2C_S + C_{int})$$

Therefore C_L must be specified greater than $C_{int} / 2 + C_S$ in order to select C_{ext} properly.

After C_L (crystal load capacitance) is properly selected, care should be taken to make sure the crystal is not operating in an excessive drive level specified by the crystal manufacturer. Otherwise, the crystal will age quickly and that in turn will affect the operating frequency of the crystal.

For detail considerations of crystal oscillator design, please refer to **AN-06**.

2.4 Serial Port Control for CH7025/CH7026

• SPC and SPD

SPD and SPC function as a serial interface where SPD is bi-directional data and SPC is an input only serial clock. In the reference design, SPD and SPC pins are pulled up to VDDIO (+1.2V ~ +3.3V) with 6.8kΩ resistors as shown in **Figure 4**.

• AS

This pin determines the serial port address of CH7025/CH7026. Address = 75h when AS is high. Address = 76h when AS is low. See **Figure 4** for detail.

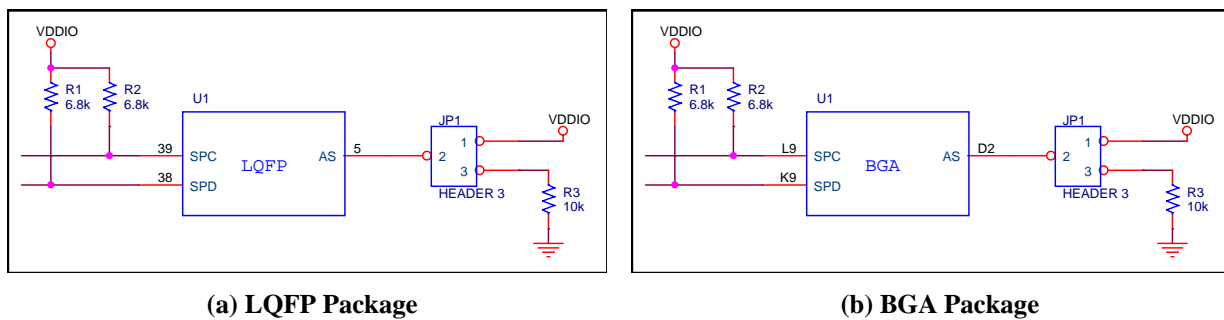

Figure 4: Serial Port Control

2.5 Input Pins

• Data Inputs

CH7025/CH7026 can accept up to 24 data inputs, as shown in **Figure 5**, from a digital video port of a graphics controller. The swing is defined by VDDIO (1.2 ~ 3.3V).

Unused Data input pins can be left open or pulled down with 10kΩ resistors.

• H/V Sync Pins

The horizontal/vertical sync pins can be used as inputs as shown in **Figure 5**.

• DE/CSB

The DE/CSB pin is used as a data input indicator (See **Figure 5**). When the pin is high, the input data is active. When the pin is low, the input data is blanking.

• GCLK

The GCLK input is the clock signal input to the device for using with the H, V, DE and D[23:0] data.

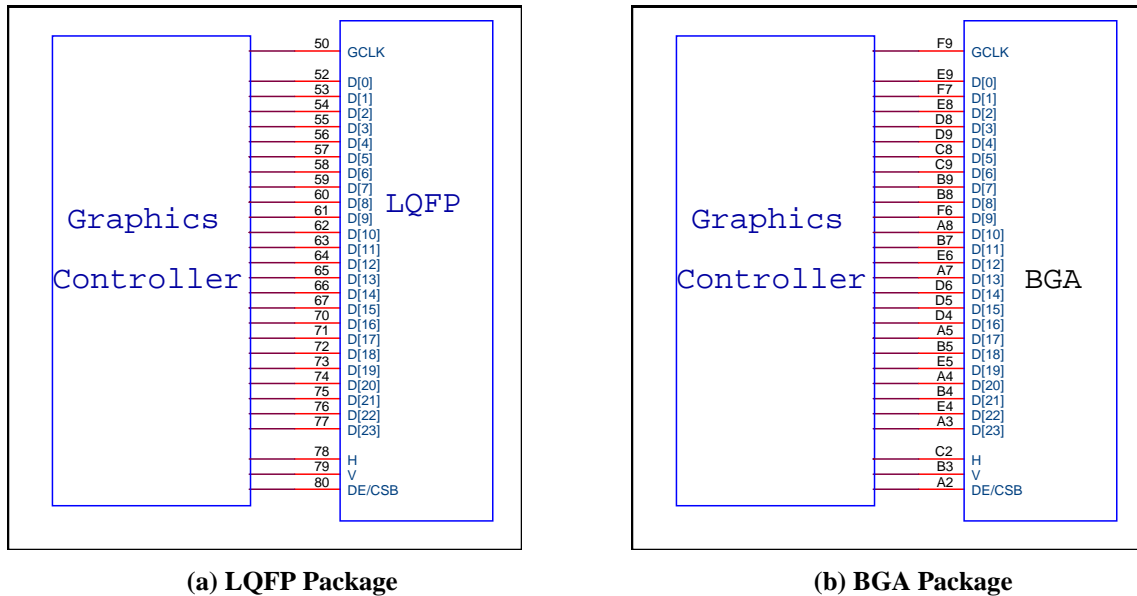

Figure 5: CH7025/CH7026 Input Pins

2.6 Miscellaneous Pins

• ATPG

The ATPG pin should be left open or pulled low with a 10kΩ resistor in the application as shown in Figure 6.

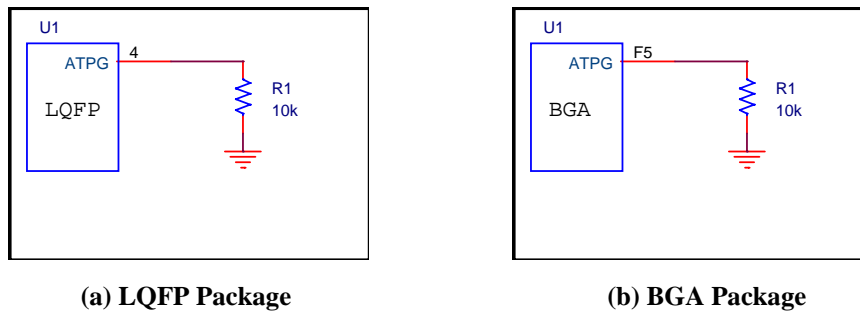

Figure 6: ATPG Pin

2.7 TV Video Outputs

• DAC0~2

Three on-chip 10-bit high speed DACs provide flexible output capabilities, such as single, double or triple CVBS output, YPbPr output, RGB output and simultaneous CVBS and S-video output. If the DACs require a double termination, a 75 Ω resistor should be placed between each DAC pin and the ground as shown in Figure 7.

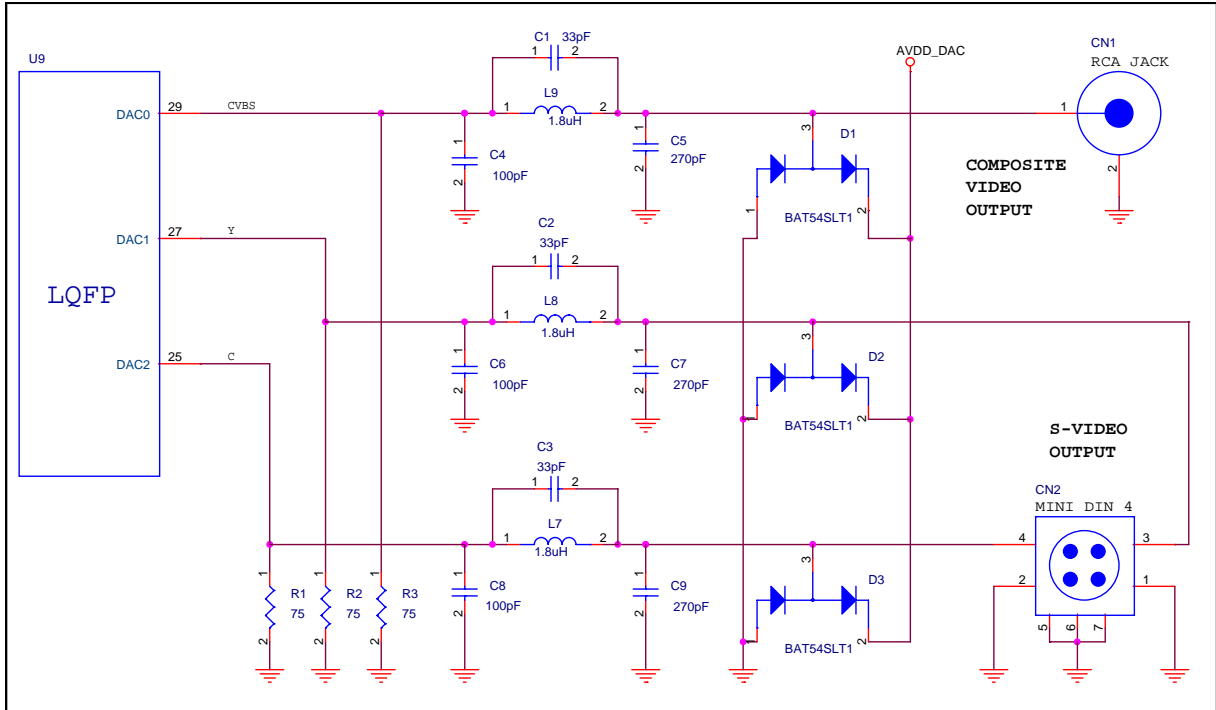

Figure 7(a): CH7025/CH7026 Video Output - LQFP

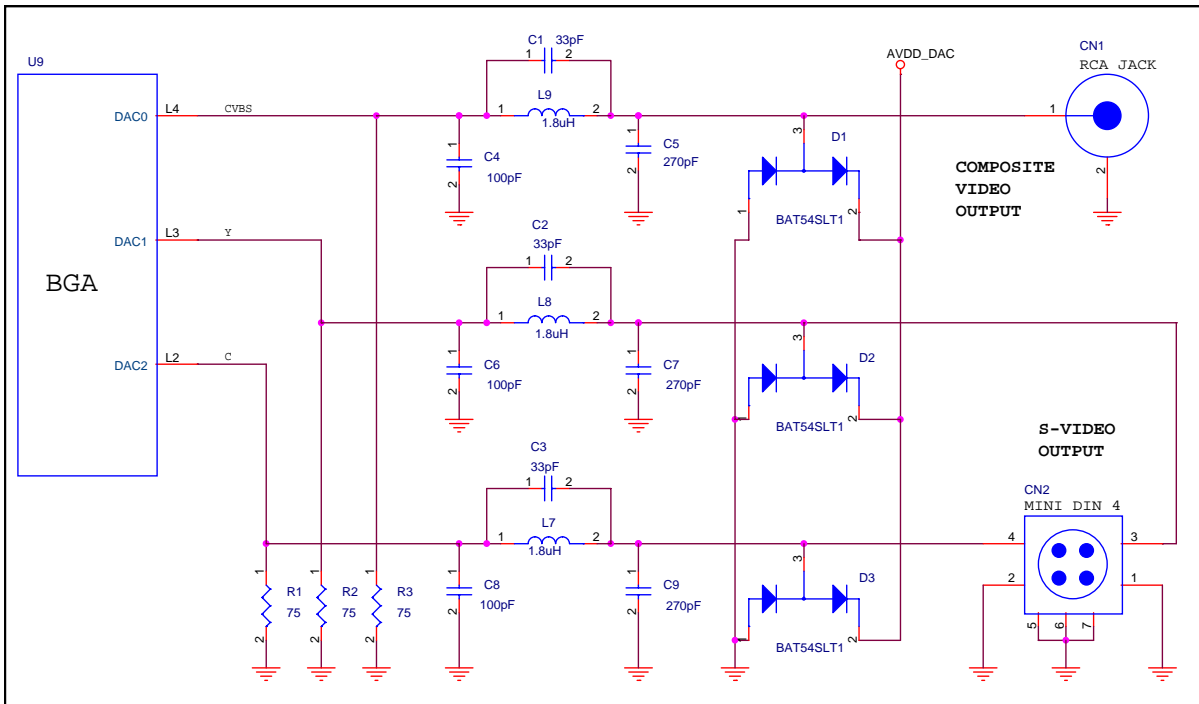

Figure 7(b): CH7025/CH7026 Video Output - BGA

In order to minimize the hazard of ESD, a set of protection diodes are highly recommended for each DAC Output.

3.0 Reference Design Example

The following reference schematic of CH7025/CH7026 is provided here for design reference only. We encourage those who will engage in an application design with CH7025/CH7026 to contact Chronitel Applications group. **Table 4** provides the BOM list for the reference schematic.

3.1 Reference Schematic

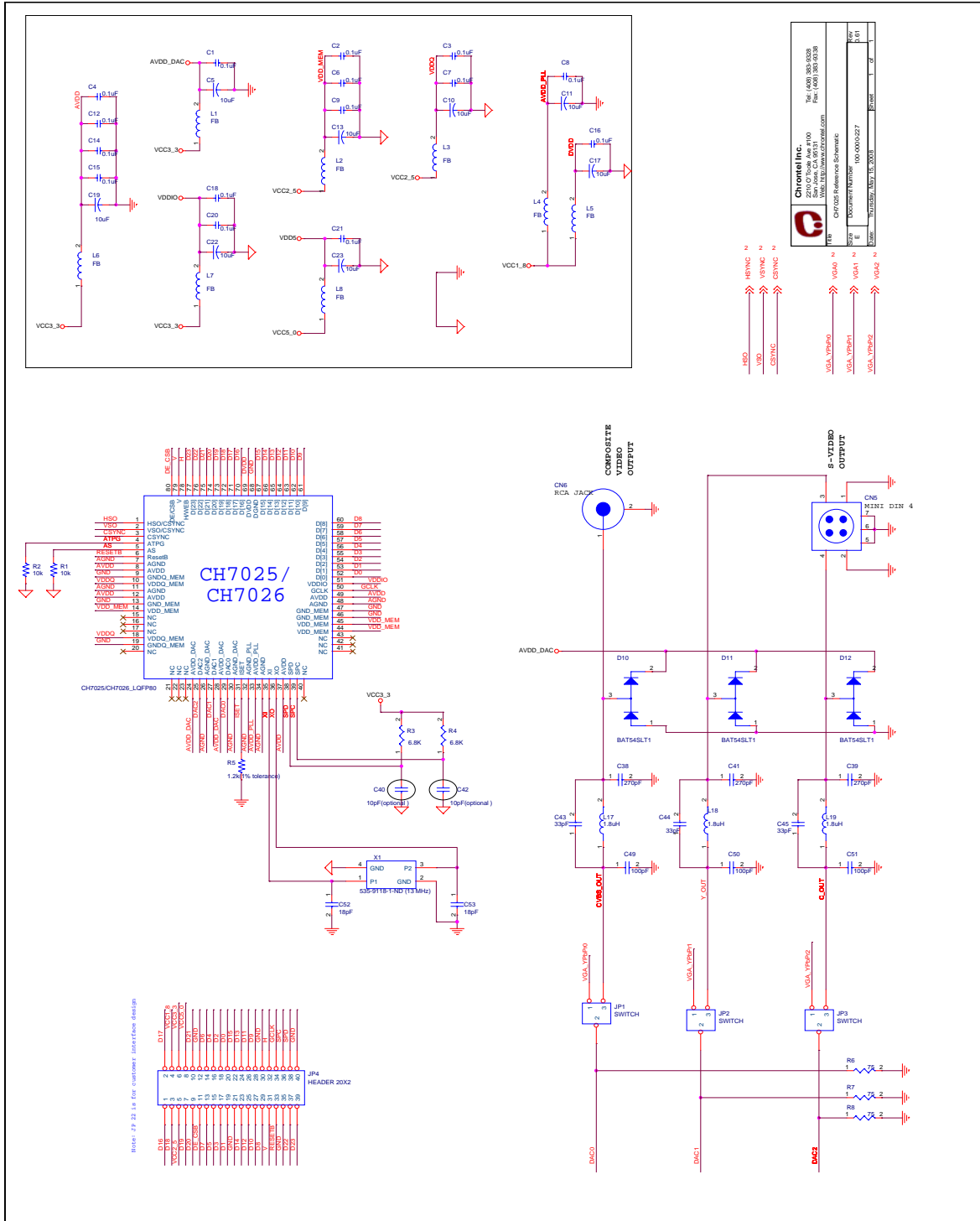

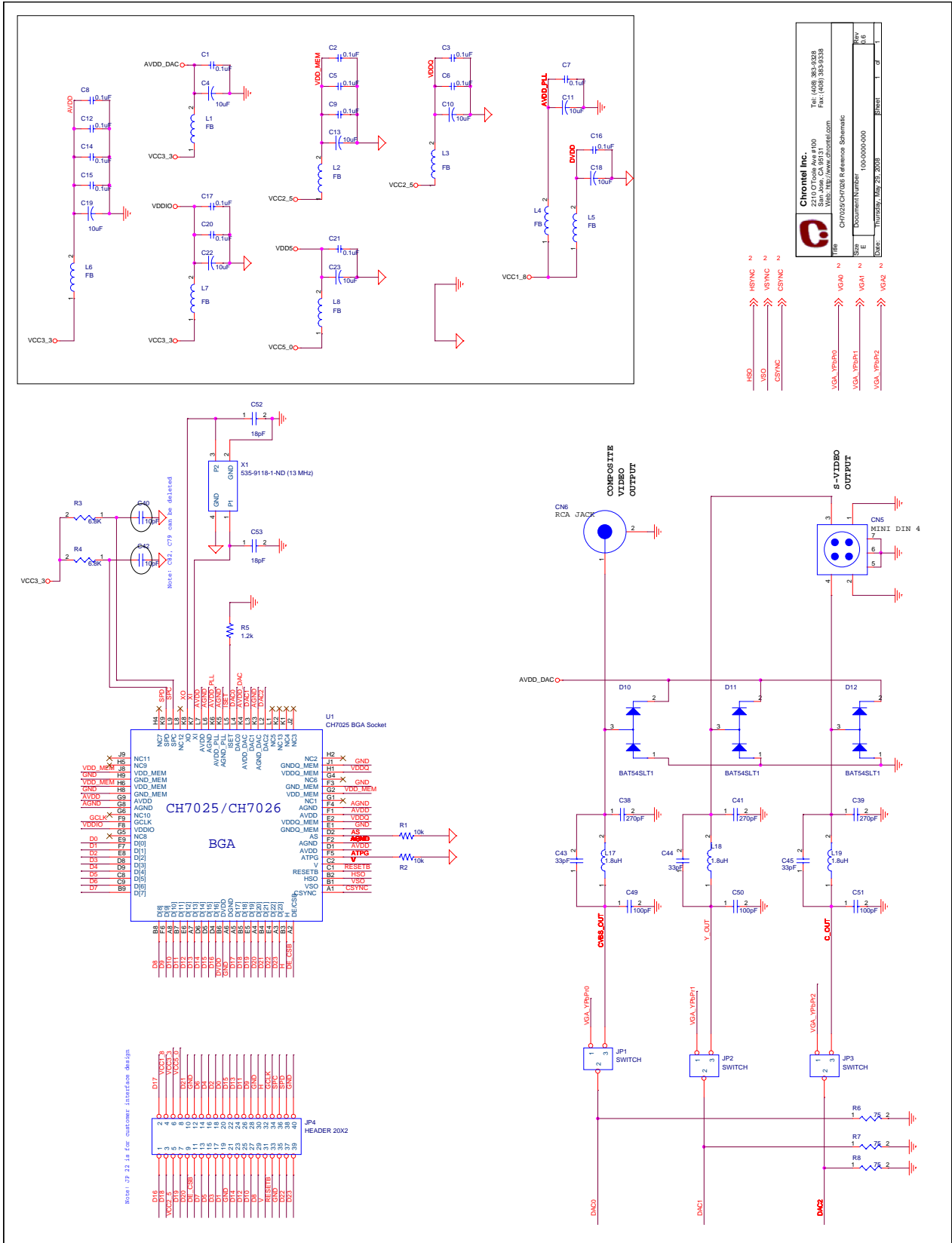

(b) BGA Package

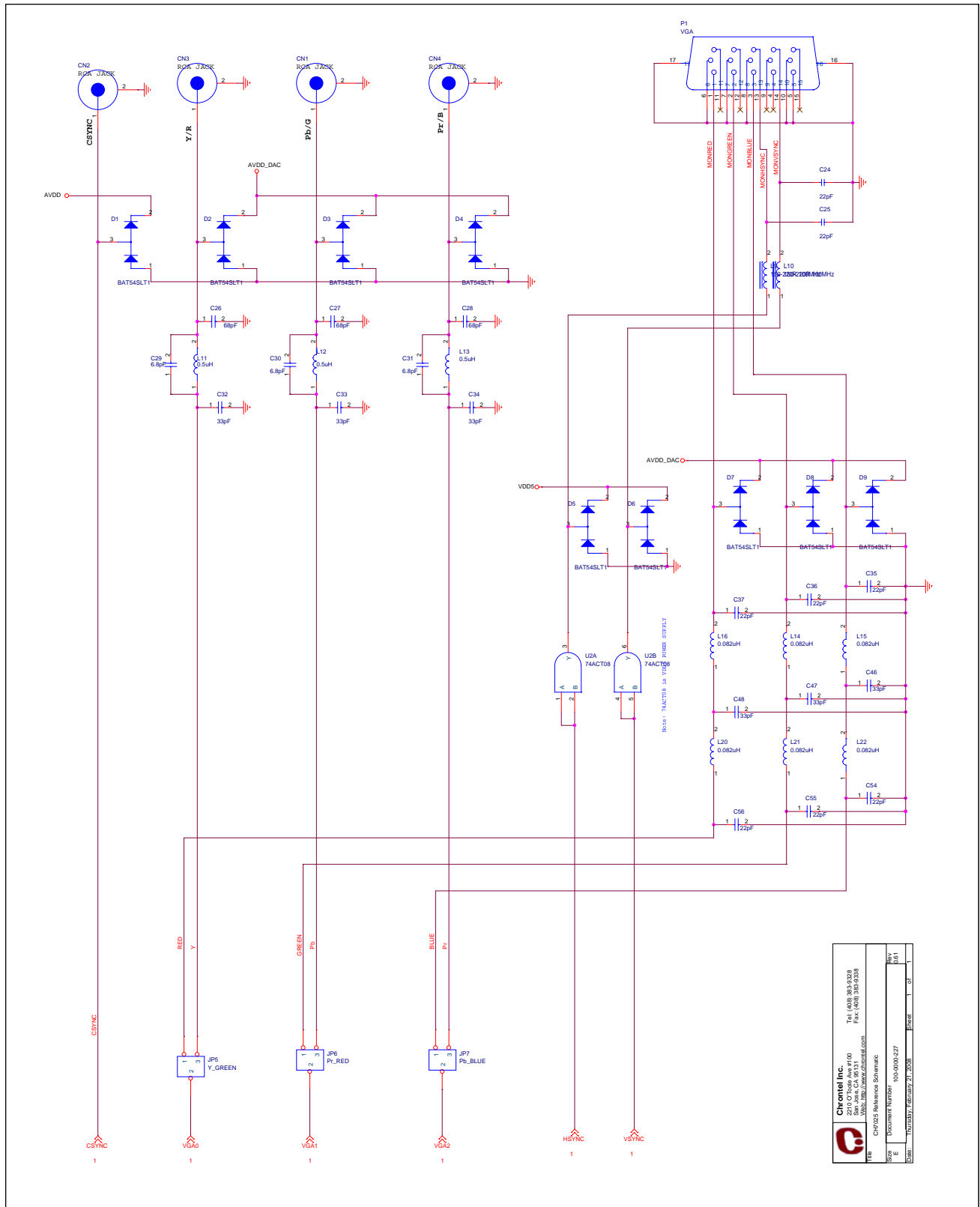

(c) Output filter

 Chronitel Inc. 2214 O'Toole Ave #100 #100 www.chronitel.com		Tel: (408) 305-9328 Fax: (408) 305-9328 www.chronitel.com
Title: CH7025 Reference Schematic Doc#: 100-0000-027 Date: 12/13/2008		Rev: 1 1 of 1

3.2 Reference Board Preliminary BOM

Table 4: CH7025/CH7026 Reference Design BOM List

Item	Quantity	Reference	Part
1	5	CN1,CN2,CN3,CN4,CN6	RCA Jack
2	1	CN5	4-pin Mini DIN
3	15	C1,C2,C3,C4,C6,C7,C8,C9,	0.1uF
		C12,C14,C15,C16,C18,C20,	
		C21	
4	8	C5,C10,C11,C13,C17,C19,	10uF
		C22,C23	
5	11	C24,C25,C29,C30,C31,C35,	22pF
		C36,C37,C54,C55,C56	
6	3	C26,C27,C28	220pF
7	6	C32,C33,C34,C49,C50,C51	100pF
8	3	C38,C39,C41	270pF
9	2	C40,C42	10pF(optional)
10	6	C43,C44,C45,C46,C47,C48	33pF
11	2	C52,C53	18pF
12	12	D1,D2,D3,D4,D5,D6,D7,D8,	BAT54SLT1
		D9,D10,D11,D12	
13	3	JP1, JP2, JP3, JP5, JP6, JP7	SWITCH
14	1	JP4	HEADER 20X2
15	8	L1,L2,L3,L4,L5,L6,L7,L8	FB
16	2	L9,L10	150-220R 100MHz
17	3	L11,L12,L13	1.5uH
18	6	L14,L15,L16,L20,L21,L22	0.082uH
19	3	L17,L18,L19	1.8uH
20	1	P1	VGA
21	2	R1,R2	10k
22	2	R3,R4	6.8K
23	1	R5	1.2k(1% tolerance)
24	3	R6,R7,R8	75ohm
25	1	U1	CH7025/CH7026_LQFP80
26	1	U2	74ACT08
37	1	X1	535-9118-1-ND (13 MHz)

Disclaimer

This document provides technical information for the user. Chrontel reserves the right to make changes at any time without notice to improve and supply the best possible product and is not responsible and does not assume any liability for misapplication or use outside the limits specified in this document. We provide no warranty for the use of our products and assume no liability for errors contained in this document. The customer should make sure that they have the most recent data sheet version. Customers should take appropriate action to ensure their use of the products does not infringe upon any patents. Chrontel, Inc. respects valid patent rights of third parties and does not infringe upon or assist others to infringe upon such rights.

Chrontel PRODUCTS ARE NOT AUTHORIZED FOR AND SHOULD NOT BE USED WITHIN LIFE SUPPORT SYSTEMS OR NUCLEAR FACILITY APPLICATIONS WITHOUT THE SPECIFIC WRITTEN CONSENT OF Chrontel. Life support systems are those intended to support or sustain life and whose failure to perform when used as directed can reasonably expect to result in personal injury or death.

Chrontel

Chrontel International Limited

129 Front Street, 5th floor,

Hamilton, Bermuda HM12

www.chrontel.com

E-mail: sales@chrontel.com