

## PCB Layout and Design Considerations for the CH7304 Single LVDS Transmitter

### 1. Introduction

This application note focuses on the basic PCB layout and design guidelines for the CH7304 Single LVDS Transmitter. Guidelines in component placement, power supply decoupling, grounding, and reference crystal placement and selection, input signal interface and video components for the LVDS output are discussed in this document. The guidelines discussed here are intended to optimize the PCB layout and applications for this product. They are only for reference. Designers are urged to implement the configurations and evaluate the performance of the system prior to bringing the design to production.

The discussion and figures shown in this document are based on the 64-pin LQFP package of the CH7304 designed with an Intel Brookdale<sup>®</sup> / Intel Springdale<sup>®</sup> system.

### 2. Component Placement

Components associated with the CH7304 encoder should be placed as close as possible to the respective pins. The following discussion will describe guidelines on how to connect critical pins, as well as describe the guidelines for the placement and layout of components associated with these pins.

#### 2.1 Power Supply Decoupling

The optimum power supply decoupling is accomplished by placing a 0.1 $\mu$ F ceramic capacitor to each of the power supply pins as shown in **Figure 1** and **Figure 2**. These capacitors should be connected as close as possible to their respective power and ground pins using short and wide traces to minimize lead inductance. Whenever possible, a physical connecting trace should connect the ground pins of the decoupling capacitors to the CH7304 ground pins, in addition to ground vias.

##### 2.1.1 Ground Pins

The analog and digital grounds of the CH7304 should connect to a common ground plane to provide a low impedance return path for the supply currents. Whenever possible, each of the CH7304 ground pins should connect directly to its respective decoupling capacitor ground lead, then connected to the ground plane through a ground via. Short and wide traces should be used to minimize the lead inductance. See **Table 1** for the ground pins assignment.

##### 2.1.2 Power Supply Pins

Separate digital (including the I/O supply voltage VDDV), and PLL power planes are recommended. See **Table 1** for the Power supply pins assignment.

**Table 1: Power Supply Pins Assignment**

Pin #	# of pins	Type	Symbol	Description
42, 64	2	Power	DVDD	Digital Supply Voltage (3.3V)
35, 49	2	Power	DGND	Digital Ground
48	1	Power	VDDV	I/O Supply Voltage (1.1V to 3.3V)
5, 11, 22, 28	4	Power	LVDD	LVDS Supply Voltage (3.3V)
8, 14, 19, 25, 31	5	Power	LGND	LVDS Ground
38	1	Power	LPLL_VDD	LVDS PLL Supply Voltage (3.3V)
36	1	Power	LPLL_GND	LVDS PLL Ground

**Digital and PLL Power Pins Decoupling and Connection**

Figure 1 shows the decoupling and connection for the LPLL\_VDD, LVDD, and DVDD.

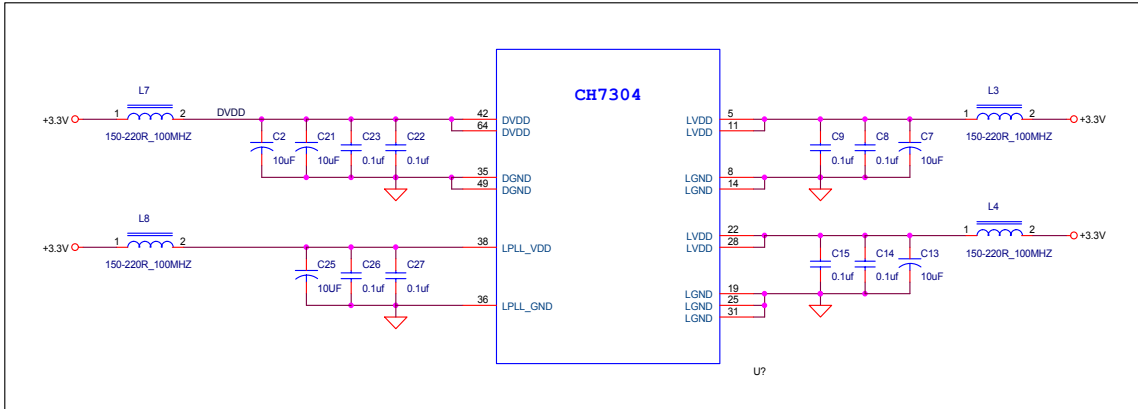

**Figure 1: Digital and PLL Power pins Decoupling and Connection**

**Note:** All the Ferrite Beads described in this document are recommended to have  $<.05 \Omega$  at DC;  $2 \Omega$  at 25MHz &  $47 \Omega$  at 100MHz. Please refer to Fair\_Rite part# 2743019447 for detail or an equivalent part can be used for the diagram.

**VDDV and VREF Decoupling and Connection**

VDDV is the I/O supply voltage. This pin should be decoupled and connected to the maximum voltage level seen by the I/O of the CH7304 (1.1V to 3.3V).

VREF inputs a reference voltage of  $VDDV/2$ . The signal is derived externally through a resistor divider and decoupling capacitor, and will be used as a reference level for data, syncs and clock inputs. Please refer to **Figure 2** for the decoupling and connection.

Figure 2 shows the decoupling and connection for VDDV, and VREF.

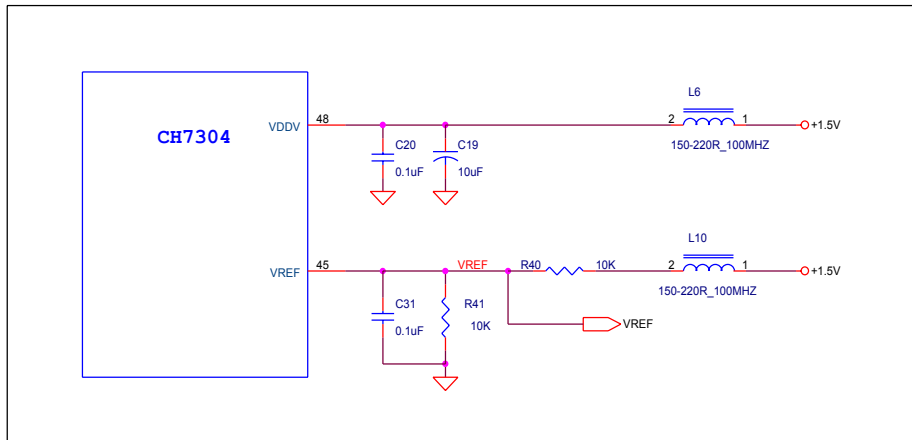

**Figure 2: VDDV and VREF pins Decoupling and Connection**

## 2.2 General Control

- **GPIO pin**

This pin provides a general purpose I/O and is controlled via the serial port. The direction of the signal is controlled by register 1Eh, GPIO Direction Control Register. When the direction is set as “input”, the GPIO pin has a weak pull-up (about 1 MΩ). See **Figure 3** for design reference. In the reference design, the GPIO pin is connected with a pair of resistors, which allow the designer to either pull up or pull down the pin. If it should be set to HIGH, R65 can be stuffed with a 10 KΩ resistor, and R66 should not be stuffed. If it is to be set to LOW, then R65 should be not stuffed, and R66 can be stuffed with a 330Ω resistor.

- **RESET\* pin**

RESET\* pin, which is internal pull-up, When this pin is low, the device is held in the power on reset condition. When this pin is high, reset is controlled through the serial port. In the reference design, this pin is connected to the RST\* pin of Intel’s DVO port.

- **LPLL\_CAP pin**

The LPLL\_CAP pin allows coupling of any signal to the on-chip loop filter capacitor. A capacitor with a typical value of 0.1 nF, should be connected between this pin (pin 37) and ground (See **Figure 3**).

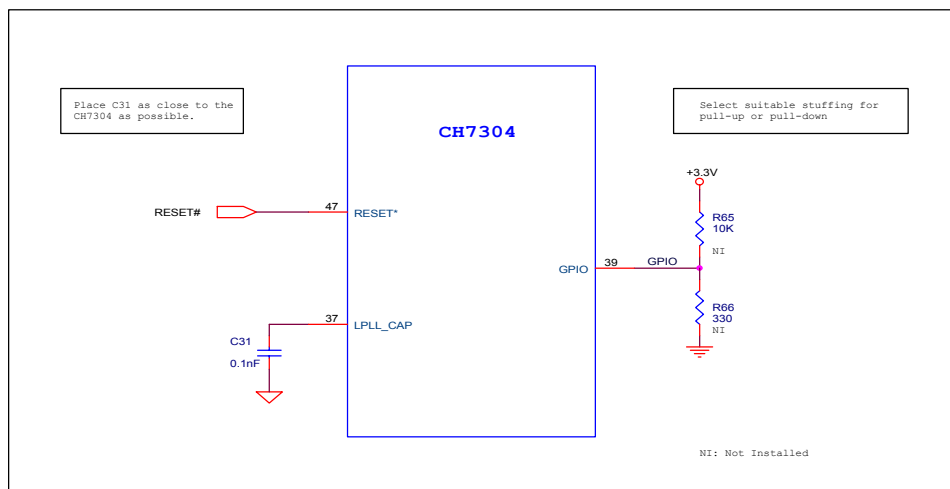

Figure 3: General Control Reference Design

## 2.3 Clock and Crystal Oscillator

- **XI/FIN and XO pins**

**Crystal Input**

The 14.31818 MHz crystal must be placed as close as possible to the XI and XO pins (pins 34 and 33), with traces connected from point to point, overlaying the ground plane. Since the crystal generates timing reference for the CH7304 encoder, it is very important that noise should not couple into these input pins. Traces with fast edge rates should not be routed under or adjacent to these pins. In addition, the ground reference of the external capacitors connected to the crystal pins must be connected very close to the CH7304 pin 35 ground.

**Reference Crystal Oscillator**

The CH7304 includes an oscillator circuit which allows a 14.31818MHz crystal to be connected directly. Alternatively, an externally generated 14.31818MHz clock source may be supplied to the CH7304. If an external clock source is used, it should have CMOS level specifications. The clock should be connected to the XI pin, and the XO pin should be left open. The external source must have low jitter characteristics.

If a crystal is used, the designer should ensure that the following conditions are met:

The crystal is specified to be 14.31818 MHz and in parallel resonance (NOT series resonance). The crystal should also have a load capacitance equal to its specified value ( $C_L$ ).

External load capacitors have their ground connection very close to the CH7304 ( $C_{ext}$ ).

To allow tunability, a variable cap may be connected from XI/FIN to ground.

Note that the XI/FIN and XO pins each has approximately 10 pF ( $C_{int}$ ) of shunt capacitance internal to the device. To calculate the proper external load capacitance to be added to the XI/FIN and XO pins, the following calculation should be used:

$$C_{ext} = (2 \times C_L) - C_{int} - 2C_S$$

where:

$C_{ext}$  = external load capacitance required on XI and XO pins.

$C_L$  = crystal load capacitance specified by crystal manufacturer.

$C_{int}$  = capacitance internal to CH7304 (approximately 10-15 pF on each of XI and XO pins).

$C_S$  = stray capacitance of the circuit (i.e. routing capacitance on the PCB, associated capacitance of crystal holder from pin to pin etc.).

Please refer to **Figure 4** for the symbols used in the calculation described above.

In general, let us assume

$$C_{int\ XI} = C_{int\ XO} = C_{int}$$

$$C_{ext\ XI} = C_{ext\ XO} = C_{ext}$$

such that

$$C_L = (C_{int} + C_{ext}) / 2 + C_S \quad \text{and} \quad C_{ext} = 2(C_L - C_S) - C_{int}$$

$$= 2C_L - (2C_S + C_{int})$$

Therefore  $C_L$  must be specified greater than  $C_{int}/2 + C_S$  in order to select  $C_{ext}$  properly.

After  $C_L$  (crystal load capacitance) is properly selected, care should be taken to make sure the crystal is not operating in an excessive drive level specified by the crystal manufacturer. Otherwise, the crystal will age quickly and that in turn will affect the operating frequency of the crystal.

For detail considerations of crystal oscillator design, please refer to AN-06.



## 2.4 Serial Ports Control

- **SPD and SPC pins**

SPD (pin 41) and SPC (pin 40) function as a serial interface where SPD is bi-directional data and SPC is an input only serial clock. In the reference design, SPD and SPC are pulled up with 2.2 KΩ resistors.

The Device Address Byte of the CH7304 is defined as {1 1 1 0 1 0 1 R/W}. For serial port writes, the Device Address Byte is EAh and for serial port reads, the Device Address Byte is EBh.

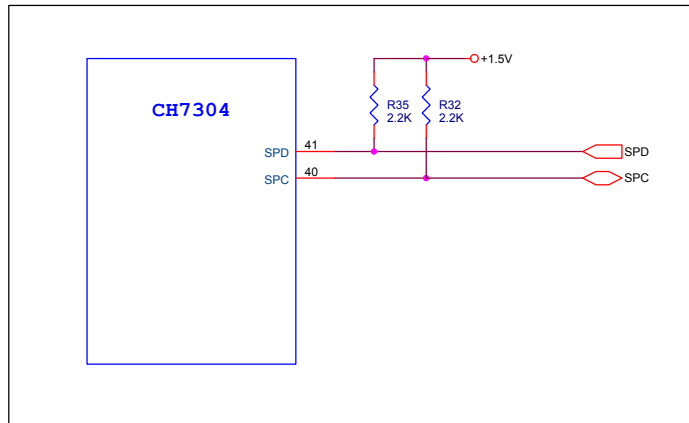

Figure 6: Serial Port Control Reference Design

## 2.5 Data Input and Syncs

Since the digital pixel data and the pixel clock of the CH7304 may toggle at speeds of up to 165MHz (depending on the input mode), it is critical that the connection of these video input signals between the graphics controller and the CH7304 be kept short and isolated as much as possible from the analog outputs and analog circuitry. For optimum performance, these signals should not overlay the analog power or analog output signals.

- **D[11:0]**

These data pins accept a set of 12 data inputs from a digital video port of a graphics controller. The levels are from 0 to VDDV. VREF is the threshold level. The DATA signals are single ended high speed signals that should be routed together as a bus. It is recommended that 8 mil traces be used when routing these signals.

- **H and V**

These pins accept horizontal/vertical sync inputs for use with the D[11:0] input data. The amplitude will be 0 to VDDV. VREF is the threshold level for these inputs.

Figure 7 shows the reference design example for data input and syncs.

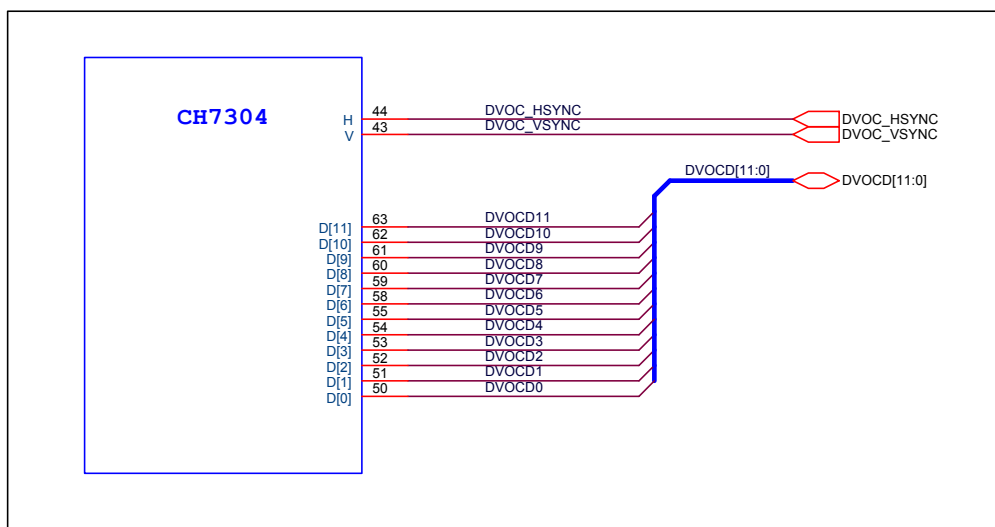

Figure 7: Data Input and Syncs Reference Design

## 2.6 LVDS Output and Control

The LVDS output pins include: LDC[3:0], LLC, LLC\*. The LVDS control pins include: VSWING, DE, ENAVDD, and ENABKL. The connection of these pins are described as follows. **Figure 8** shows a reference design example for LVDS output and control.

- **VSWING**

VSWING is the LVDS swing control. This pin sets the swing level of the LVDS outputs. A 2.4 K $\Omega$  resistor should be connected between this pin and LGND (pin 31) using short and wide traces.

- **DE**

DE is the Data Enable control pin.

This pin accepts a data enable signal which is high when active video data is input to the device, and remains low during all other times. The levels are from 0 to VDDV. VREF is the threshold level.

- **ENAVDD, ENABKL**

ENAVDD (pin 2) and ENABKL (pin 1) are for LVDS panel power control: ENAVDD enables the panel's 3.3V VDD and ENABKL enables the panel's back-light. In the reference design, these pins are connected to the panel's VDD and backlight control circuits respectively.

- **LDC[3:0], LLC, LLC\***

The LDC[3:0], LLC, LLC\* signals are high frequency differential signals that need to be routed with special precautions. They must be routed in pairs with the length as close as possible. The maximum length difference must not exceed 100 mils for any of the pairs relative to each other. The number of bends should be kept to 4 or less and 45 degree is the maximum corner angle. These signals should be routed on the top layer directly to the connector without any vias to the bottom layer. Trace for the LVDS signals should be closely coupled and the trace should be 100 $\Omega$  differential impedance (50 $\Omega$  to the ground from each differential pin).

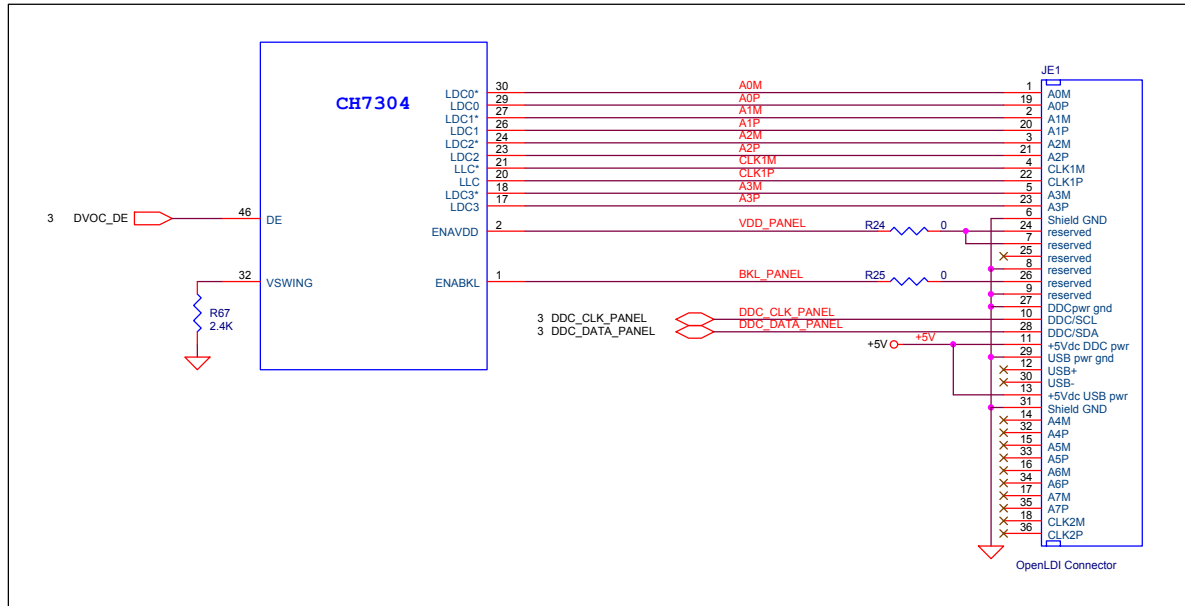

Figure 8: LVDS Output and Control Reference Design

### 3. LVDS Output Design Tips

#### Output and Control Reference Design

- Dedicating planes for Vcc and Ground are typically required for high-speed design. The solid ground plane is required to establish a controlled impedance for the transmission line interconnects. A narrow spacing between power and ground can also create an excellent high frequency bypass capacitance.
- If it is possible, put CMOS/TTL signals and LVDS signals on a different layers which should be isolated by the power and ground planes.
- Power and ground should use wide (low impedance) traces. Do not use 50Ω design rules on power and ground traces.
- Keep ground PCB return paths short and wide. Provide a return path that creates the smallest loop for the image currents to return.
- Traces for LVDS signals should be closely-coupled and designed for 100Ω differential impedance. This not only reduces EMI, but also helps to ensure noise coupled onto the conductors will be common-mode noise.
- Leave all unused LVDS and CMOS/TTL output open. Do not tie them to ground.
- Tie unused transmitter inputs and control/enable signals to power or ground using pull-up or a pull-down resistors.

## **4. Reference Design Example**

The following schematic are given to be used as a CH7304 PCB design example only. It is not a complete design. Those who are seriously doing an application design with the CH7304 and would like to have a complete reference design schematic, should contact Applications within Chrontel, Inc.

### **4.1 Schematics of Reference Design Example**

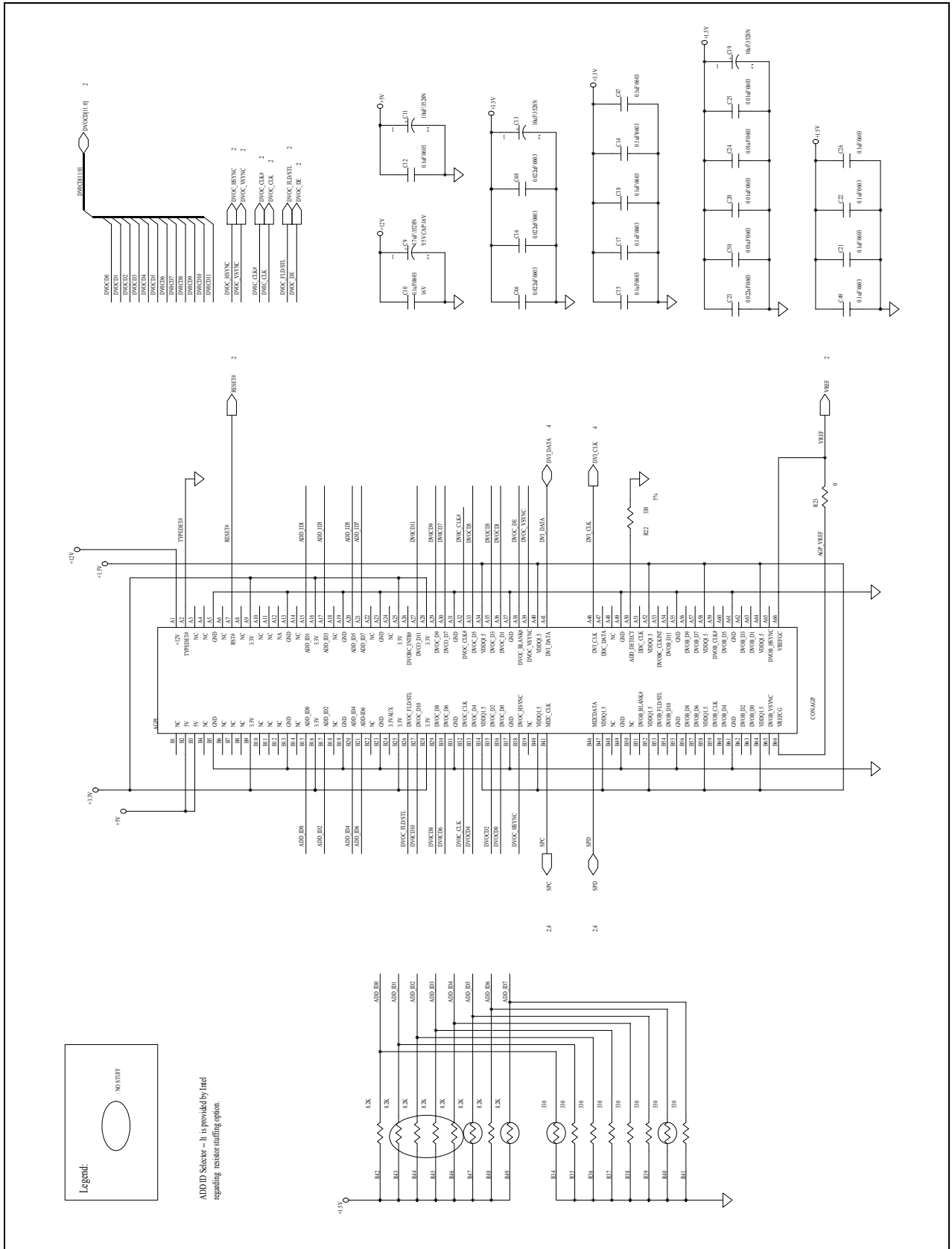

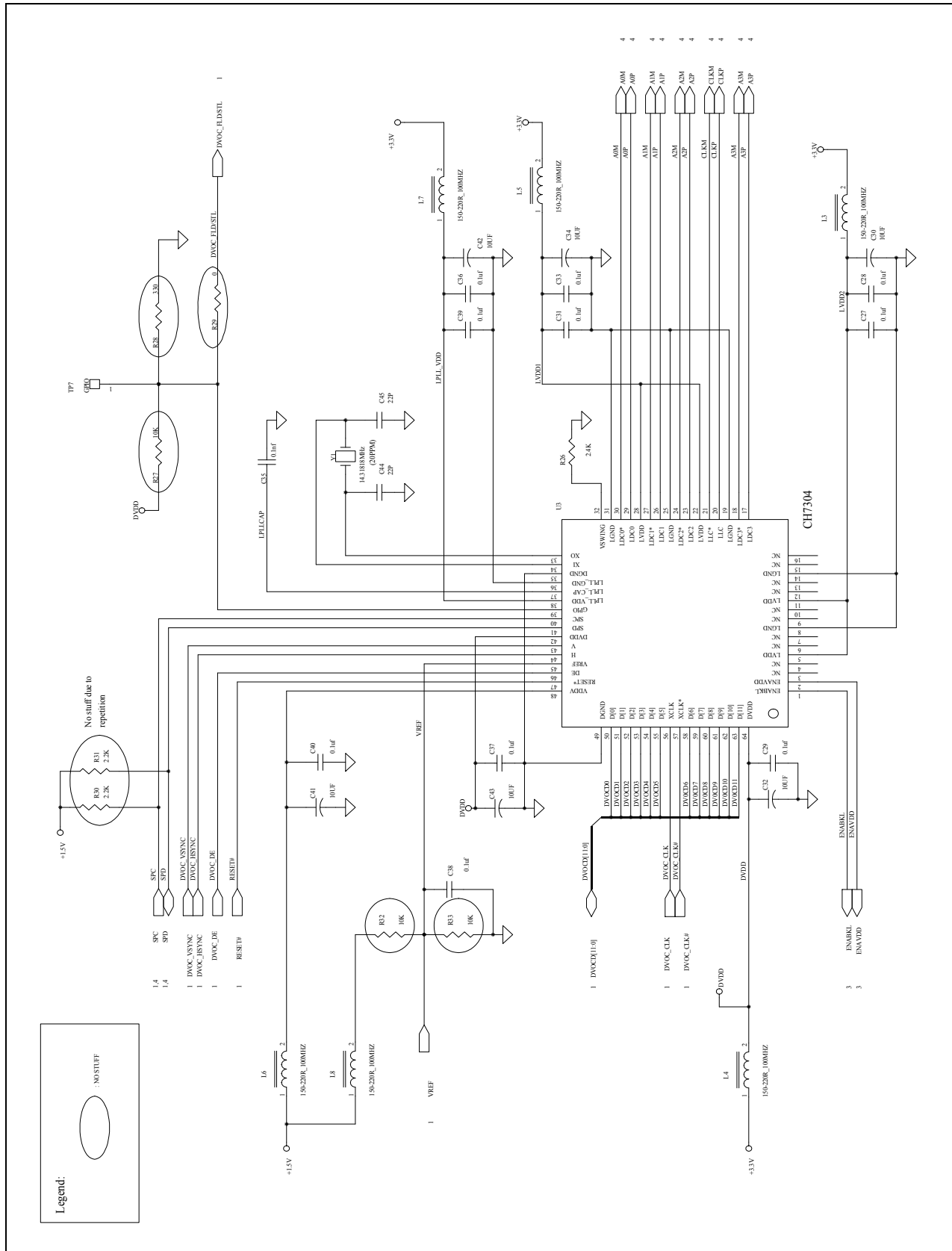

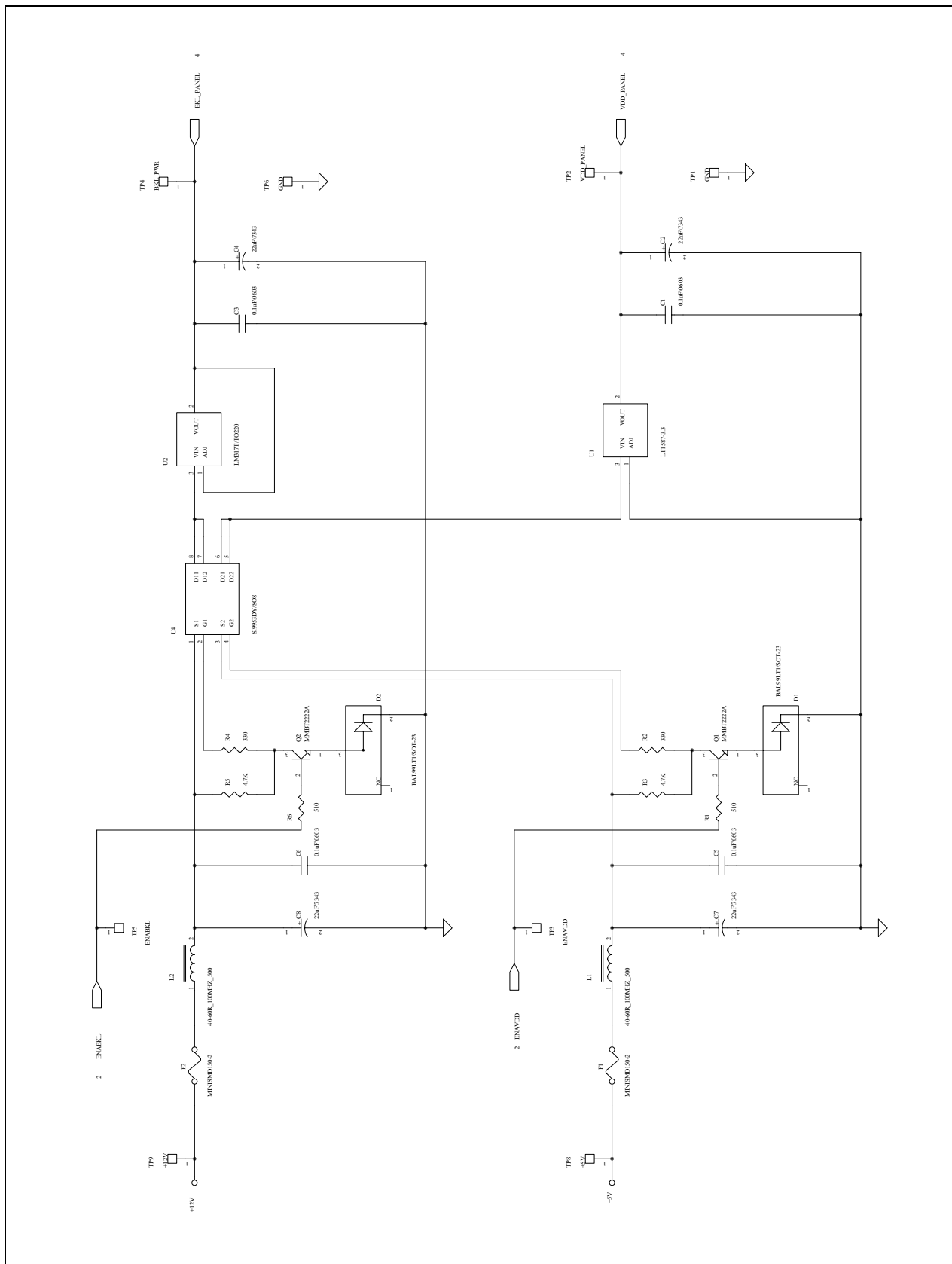

Open LDI Connector

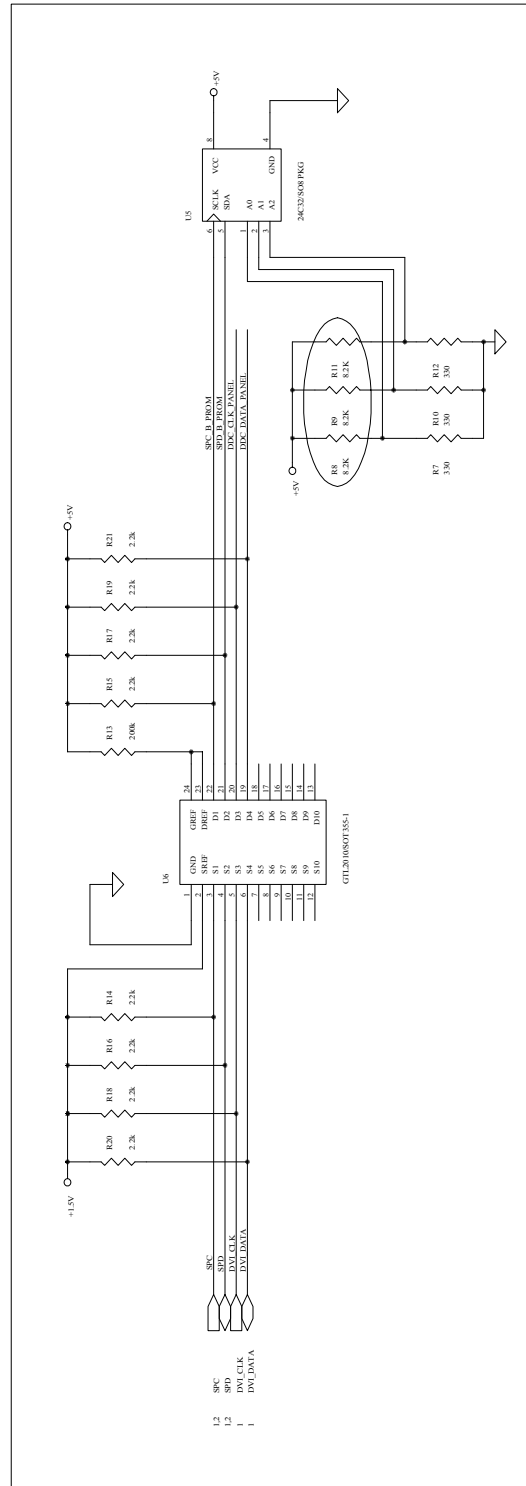
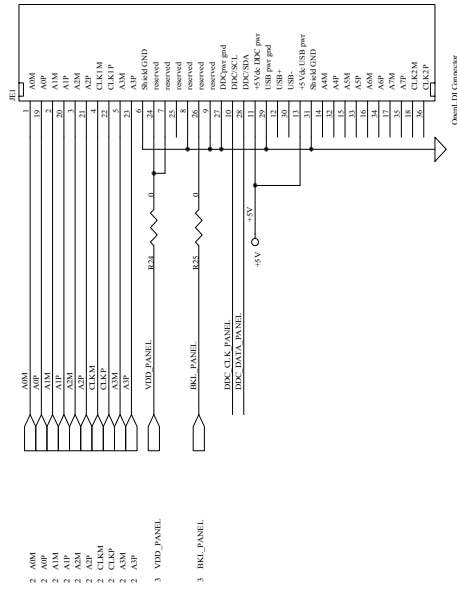

**5. Revision History**

<b>Rev. #</b>	<b>Date</b>	<b>Section</b>	<b>Description</b>
1.0	2/12/03	All	First official release.

### **Disclaimer**

This document provides technical information for the user. Chrontel reserves the right to make changes at any time without notice to improve and supply the best possible product and is not responsible and does not assume any liability for misapplication or use outside the limits specified in this document. We provide no warranty for the use of our products and assume no liability for errors contained in this document. The customer should make sure that they have the most recent data sheet version. Customers should take appropriate action to ensure their use of the products does not infringe upon any patents. Chrontel, Inc. respects valid patent rights of third parties and does not infringe upon or assist others to infringe upon such rights.

Chrontel PRODUCTS ARE NOT AUTHORIZED FOR AND SHOULD NOT BE USED WITHIN LIFE SUPPORT SYSTEMS OR NUCLEAR FACILITY APPLICATIONS WITHOUT THE SPECIFIC WRITTEN CONSENT OF Chrontel. Life support systems are those intended to support or sustain life and whose failure to perform when used as directed can reasonably expect to result in personal injury or death.

---

# **Chrontel**

**2210 O'Toole Avenue, Suite 100,  
San Jose, CA 95131-1326  
Tel: (408) 383-9328  
Fax: (408) 383-9338  
www.chrontel.com  
E-mail: sales@chrontel.com**

©2002 Chrontel, Inc. All Rights Reserved.

Printed in the U.S.A.